

LEWCO Conveyors

by LEWCO, Inc.

Installation, Operation & Maintenance Manual

Model HDSB Heavy Duty Slider Bed Belt Conveyor

Effective: January, 2007

Rev: 00

Copyright© 2006 LEWCO, Inc

Contents

Safety 3
Hazard Labels 3
Safety Considerations..... 3
 Guards and Guarding..... 3
 Operation & Use..... 4
 Maintenance & Troubleshooting 4
 Before Re-Starting the Conveyor 4
Support Installation 5
Conveyor Set Up..... 5
Belt Installation and Tracking Procedure 6
Pre-Startup Checks 6
Maintenance 7
 Maintenance Intervals 7
 Maintenance Procedures 8
 Sprocket and Chain Maintenance 8
 Belt 8
 Motor and Reducer..... 8
 Rollers and Bearings 8
 Conveyor Bed and Supports 8
 Cleaning 9
Troubleshooting 9
Replacement Parts 10
How to Order 10

Safety

Hazard Labels

- To reduce the possibility of injury to personnel operating or in the vicinity of LEWCO conveying equipment, warning signs are posted at potential hazard points on the equipment. Examine this equipment and become familiar with potential hazard areas.
- Instruct all personnel to heed these potential hazard areas.
- The following illustrations represent the typical hazard signs found at hazardous areas on LEWCO Conveyors.



Safety Considerations

Guards and Guarding

All LEWCO standard conveyor equipment is equipped with standard machine guarding methods. It is the responsibility of the owner, however, to ensure that proper guarding methods are present to comply with OSHA Standards – 29 CFR – 1910.212 Machinery and Machine Guarding. Special consideration should be given to areas where multiple pieces of equipment interface.

1910.212(a)

Machine guarding.

1910.212(a)(1)

Types of guarding. One or more methods of machine guarding shall be provided to protect the operator and other employees in the machine area from hazards such as those created by point of operation, ingoing nip points, rotating parts, flying chips and sparks. Examples of guarding methods are barrier guards, two-hand tripping devices, electronic safety devices, etc.

1910.212(a)(2)

General requirements for machine guards. Guards shall be affixed to the machine where possible and secured elsewhere if for any reason attachment to the machine is not possible. The guard shall be such that it does not offer an accident hazard in itself.

1910.212(a)(3)

Point of operation guarding.

1910.212(a)(3)(i)

Point of operation is the area on a machine where work is actually performed upon the material being processed.

1910.212(a)(3)(ii)

The point of operation of machines whose operation exposes an employee to injury, shall be guarded. The guarding device shall be in conformity with any appropriate standards thereof, or, in the absence of applicable specific standards, shall be so designed and constructed as to prevent the operator from having any part of his body in the danger zone during the operating cycle.

1910.212(a)(3)(iii)

Special hand tools for placing and removing material shall be such as to permit easy handling of material without the operator placing a hand in the danger zone. Such tools shall not be in lieu of other guarding required by this section, but can only be used to supplement protection provided.

Operation & Use

- Only experienced and trained personnel should operate the conveyor.
- Personnel should be trained in operation under normal and emergency conditions.
- Personnel on or near the conveyor should be instructed as to the location and operation of stopping devices.
- Keep starting and stopping controls free from obstructions, and instruct personnel working at or near the conveyor of their locations.
- Do not wear loose clothing while operating the conveyor. Long hair and jewelry are potential hazards of entanglement.
- Watch for hazardous conditions—sharp edges and protruding parts, etc.
- Use the conveyor to transport only material it is capable of being handled safely.
- Keep area around loading and unloading points free from obstructions.
- Prohibit personnel from riding on the conveyor.
- Before turning the conveyor ON, inspect it for foreign objects that could injure personnel or damage the equipment.
- Alert personnel in the area prior to starting conveyor.
- Check belt tracking to make sure it is running straight on the conveyor.
- After startup, make sure all areas of the conveyor are operating properly.

Maintenance & Troubleshooting

- Only experienced and trained personnel should perform maintenance, including lubrication and adjustments.
- A maintenance program should be established to insure that all conveyor components are maintained in a condition which does not constitute a hazard to personnel.
- Turn OFF and lockout the main power switches to the conveyor, following lockout/tagout procedures.
- Do not perform any work on the conveyor while it is running unless the nature of the maintenance absolutely requires operation of the conveyor. If the conveyor must be operated to perform maintenance procedures, allow only experienced conveyor maintenance personnel to do the work.
- Do not wear loose clothing while performing maintenance on an operating conveyor.
- Use extreme care when using mechanical aids such as hoists, cables, and other equipment to perform maintenance. They can cause damage to the conveyor and cause a dangerous condition when the conveyor is turned on.
- Poor housekeeping practices cause accidents and inefficient conveyor operation. Keep area and conveyor clean from spilled lubricants and other materials. Make sure no material is caught or lodged in the movable parts of the conveyor unless necessary during maintenance.

Before Re-Starting the Conveyor

- Inspect the conveyor and make certain all safety devices and guards are in place.
- Make sure all tools and/or maintenance equipment have been removed from the conveyor area.
- Make sure no material is caught or lodged in the movable parts of the conveyor.
- Make sure all personnel are clear of the conveyor and are alerted that the conveyor is about to be started.
- Allow only authorized personnel to start the conveyor following maintenance or any emergency shut-off.

Support Installation

- Bolts for attaching the supports to the bed sections are shipped in a bag attached to the supports or in a separate box.
- Set the support height. Subtract frame height dimension from desired conveying surface. See Figure 2.1. Adjust the supports to this dimension by sliding inner and outer legs and tighten bolts.
- Supports should be located at ends of conveyor and centered under each splice on multi-piece conveyors (nominal 10' centers).
- If supports are located on nominal 5' centers, center additional supports midway between supports at splices.

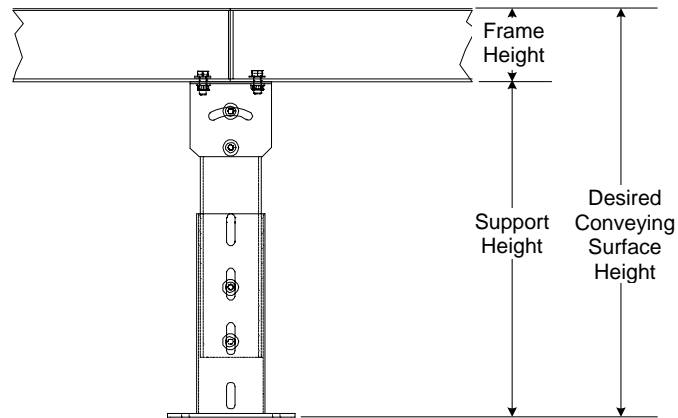

Figure 2.1 – Support Height Adjustment

Conveyor Set Up

- Mark a chalk line on floor to locate center of the conveyor.
- Place the drive section in position.
- Install remaining sections in order. Conveyor sections have a section number label, which includes the Sales Order number, Line Item number, and Section Assembly number (last two digits). Conveyors made up of more than one section are to be assembled in ascending numerical order, starting with Section Assembly 01 at the product infeed end.
- Check that conveyor is level across both width and length of conveyor. Adjust supports if necessary.
- Check all bed sections for square. See Figure 3.1. Use a string stretched from opposing corners at edge of bed to aid in straightening conveyor. Ensure that both dimensions are the same. Adjust or shim supports as required. Both sides of the conveyor must be in the same plane (bed not twisted).

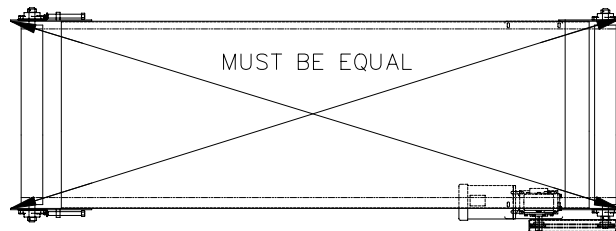

Figure 3.1 Check the bed for square

- Tighten all butt couplings and support mounting bolts and lag conveyor to floor.
- Install and track belt.

Belt Installation and Tracking Procedure

- Install belt per Figure 4.1.
- Prior to starting the conveyor, again ensure that all pulleys and rollers are square and level. Initially, avoid the situation shown in Figure 4.2.
- Start the conveyor.
- Check for proper belt tension. When properly adjusted, there should be no slippage between the drive pulley and the conveyor belt and the drive motor amp draw will be under the rated full load amps as indicated on the motor name-plate.
- If the belt slips on the drive pulley, more tension is required. Adjust the take-up pulley to increase the tension on the belt. Make small, even adjustments; monitoring the results before readjusting.
- If the belt is over-tensioned, the belt lacing will pull away and the motor amp draw will be high. Adjust the take-up pulley to decrease the tension on the belt. Make small, even adjustments; monitoring the results before readjusting.
- Review belt position at all pulleys. Track belt if necessary based on Figure 4.2.

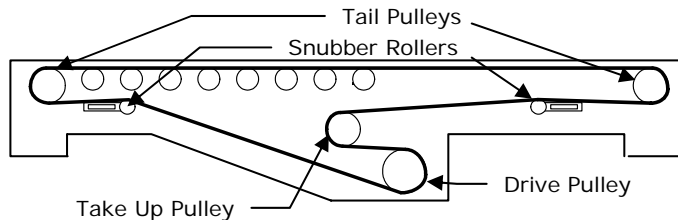

Figure 4.1 – Center Drive Belt Routing (roller bed shown, same for slider bed)

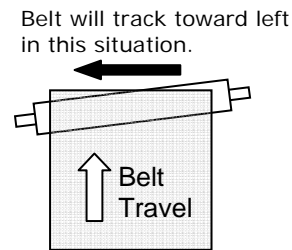

Figure 4.2 – Pulley Adjustment for Belt Tracking (Plan View)

Pre-Startup Checks

- MOST speed reducers are shipped with oil, HOWEVER, DO check for proper oil level before operating the conveyor.
- CHECK FOR REDUCER VENT PLUG AND INSTALL IF NECESSARY. See Figure 5.1. To install, remove the solid plug and replace with vent plug.
- Remove drive chain guard and inspect drive chain and sprockets.
- Chain should have sag on the slack side per Figure 5.2. Measure the sag half way between the two sprockets.
- Sag should be ¼" or 2% of the sprocket center distance.
- Inspect drive sprocket and pulley set screws. These should be tight against the reducer and pulley shafts. Using a straight edge check to assure the sprockets are aligned by placing the straight edge flush against the sprocket flanges.
- Re-install chain guard after inspection.

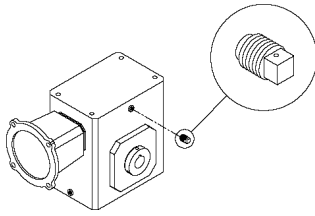

Figure 5.1 Reducer Vent Plug Installation

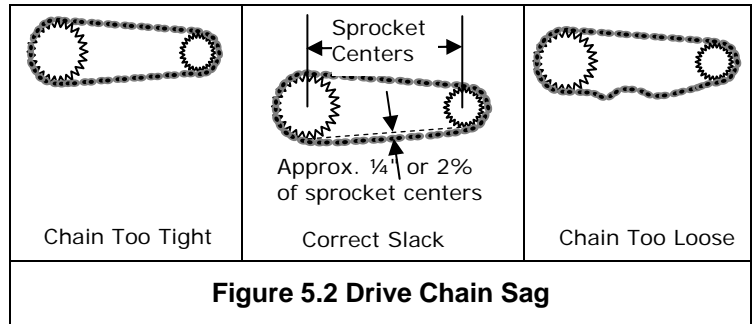

Figure 5.2 Drive Chain Sag

Maintenance

Effective operation and useful life of any equipment is directly related to the care and service it receives. A pre-determined maintenance schedule, including inspection, lubrication and cleaning should be established for each conveyor. Establish and maintain "Log Sheets" on each conveyor to record date and results of inspections, lubrication, and parts replacements. General inspections of all conveyors should be performed at regular intervals depending on use and service conditions.

Maintenance Intervals

The following chart gives a brief overview of what maintenance should be performed on a periodic basis.

COMPONENT	ACTION	SCHEDULE		
		WEEKLY	MONTHLY	QUARTERLY
MOTOR	Check noise.		✓	
	Check temperature.	✓		
	Check mounting bolts.		✓	
REDUCER	Check noise.		✓	
	Check temperature.		✓	
	Check oil level.			✓
DRIVE CHAIN	Check tension.			✓
	Lubricate.	✓		
	Check for wear.			
SPROCKETS	Check for wear.			✓
	Check set screws and keys.			✓
BELT	Check tracking.		✓	
	Check tension.		✓	
	Check lacing.	✓		
BEARINGS (Pulleys & rollers)	Check noise.		✓	
	Check mounting bolts.			✓
STRUCTURAL	General check: Loose bolts etc. tightened.		✓	

Maintenance Procedures

Sprocket and Chain Maintenance

- Remove drive chain guard and inspect drive chain and sprockets.
- Chain should have $\frac{1}{4}$ " or 2% sag when measured on the lower run of chain half way between the two sprockets. See "Pre-Startup Checks".
- A loose chain can jump the drive sprockets and can cause sprocket wear and failure. A tight chain requires excessive motor power, and can cause chain and sprocket failure.
- Inspect drive sprocket and pulley set screws for tightness against the reducer and pulley shafts.
- Check sprocket alignment. Misalignment causes wear on one side of the sprocket. Check for a misaligned shaft or a sprocket off center.
- Check shaft bearing set screws.
- Lubricate the drive chain with SAE-30 oil approximately every 40 hours of operation. Lubricate more frequently under extreme ambient conditions. Rinse chain in solvent before lubricating.
- Re-install chain guard after inspection and maintenance.

Belt

- Check front, back, and edges of belt for wear, rips, tears, holes, and dirt accumulation. Clean belt with detergent and water. Replace belt as required.
- Check belt tension under load. The belt should be just tight enough to prevent slipping at the drive pulley with a rated load. Loose belts cause excessive wear on the drive pulley lagging, and jerky load movement. Tight belts cause tears, lacing failure, and excessive motor power.
- Check belt lacing for broken, bent, loose, or missing clips and pins. Replace lacing as required.

Motor and Reducer

- Make sure the reducer is filled to the proper level with oil. Make sure breather hole is clean and the orifice is open.
- Inspect reducer for leaks.
- Use only oil recommended by the reducer manufacturer.

Rollers and Bearings

- Check drive pulley lagging for rips, tears, and missing areas. Replace pulley as required.
- Check all rollers and pulleys for tightness. All rollers must rotate freely. If roller does not turn freely check for dirt accumulation in bearing area and clean.
- Lubricate all flange type bearings that have grease fittings. Use a NLGI Grade 2 Lithium base grease, Shell Alvania EP2, or equal. Snub roller and return roller bearings are not regreasable.
- Listen to bearing for excessive noise. Replace as required.

Conveyor Bed and Supports

- Check conveyor frame, splices, supports, and bearings for loose or missing hardware. Replace hardware as required.

Cleaning

- Periodically remove drive chains and clean by immersing in solvent and scrubbing with a wire brush. Rinse thoroughly and re-lubricate. Verify proper chain tension.
- Clean chain box and keep free of all debris.

Troubleshooting

TROUBLE	CAUSE	SOLUTION
Conveyor does not start or motor stalls.	Motor overloaded	Check conveyor loading against design parameters.
	Motor drawing excessive current.	Check circuit breaker.
Excessive wear on drive chain and/or sprockets.	Lack of lubrication.	Lubricate chain.
	Sprockets out of alignment.	Align sprockets.
	Loose drive chain.	Correct chain slack (See "Pre Startup Checks").
Loud popping and/or grinding noise.	Defective bearing.	Replace bearing.
	Loose drive sprocket set screw.	Tighten sprocket set screws and check key.
	Loose drive chain.	Correct chain slack (See "Pre Startup Checks").
Motor or reducer overheating. (Note: Many motors and reducers can be hot to the touch and still be operating within normal parameters.)	Conveyor overloaded.	Check conveyor loading against design parameters.
	Low voltage to motor.	Correct voltage level as stated on motor name plate.
	Reducer lubricant level low.	Fill reducer reservoir.
Drive pulley turns but belt does not move or moves with jerky motion.	Conveyor overloaded.	Check conveyor loading against design parameters.
	Loose belt.	Tighten belt. (See belt tensioning and adjustment section.)
	Belt wrong side up.	Install belt right side up.
Belt slips and squeals.	Belt too loose, causing insufficient traction between belt and pulley.	Lag drive pulley with rough top belting; increase tension slightly.
One part of belt creeps to one side.	Belt ends at fasteners not cut square; fasteners not joined properly.	Use T-square to cut belt ends perfectly square; replace with the correct fasteners.
	Belt is bowed.	If belt is new, this condition should straighten out after belt is run under full load tension or is "broken in"; if not, belt must be replaced.
Ply separation in belt carcass.	Edge of belt worn or broken due to excessive rubbing.	Check alignment of conveyor frame, pulleys and idlers.
	Damage by abrasive, acid, heat chemicals, mildew, or oil.	Use a belt properly compounded to resist deterioration from acids, etc.
Belt stretches excessively.	Tension on belt too high.	Reduce tension roller to a point where belt will run without slipping; lag the drive pulley.
Belt creeps to one side of tail pulley.	Tail pulley or return idlers near the tail pulley are out of alignment (not perpendicular with centerline of conveyor).	Re-align by advancing (in the direction of the return belt travel) the end of the pulley or idler to which the belt has shifted.
Belt creeps to one side of head pulley.	Head pulley or idlers immediately preceding head pulley are out of alignment (not perpendicular with centerline of conveyor).	Re-align by advancing (in the direction of belt travel) the end of the pulley or idler to which the belt has shifted.
Belt creeps to one side at one spot only on long conveyor.	One or more idlers (usually immediately preceding the trouble spot) are out of alignment (not perpendicular with centerline of conveyor).	Advance (in direction of belt travel) the end of the idler to which the belt has shifted.
	Improper loading of belt.	Loading should be in direction of belt travel and centered on belt.

TROUBLE	CAUSE	SOLUTION
	Frozen idlers or idlers not properly located.	Lubricate idlers and improve maintenance; relocate improperly placed idlers and check alignment with a T-square.
	Conveyor frame or structure are crooked or not level which causes belt to shift to low side.	Check alignment by stretching a string along edge of frame and make correction; level structure.
	Foreign material build-up on pulleys or idlers.	Clean pulleys and idlers and improve maintenance by installing scrapers or other cleaning devices; check belt carcass for "bleeding".
	Pulleys (drive, tail, idlers or snubbers) out of alignment (not perpendicular with centerline of conveyor).	Re-check and square by using a T-square against edge of conveyor and pulleys of idler.

Replacement Parts

How to Order

Provide the MODEL NUMBER, and SERIAL NUMBER [located on unit label], when ordering parts for your LEWCO Conveyor. There is one unit label on each section of conveyor.

To order parts please contact your local LEWCO distributor. If unable to contact your local distributor or the original distributor that supplied the equipment, please contact LEWCO, Inc. by phone at 419-625-4014, or Fax 419-625-1247. Ask for the conveyor sales parts department.

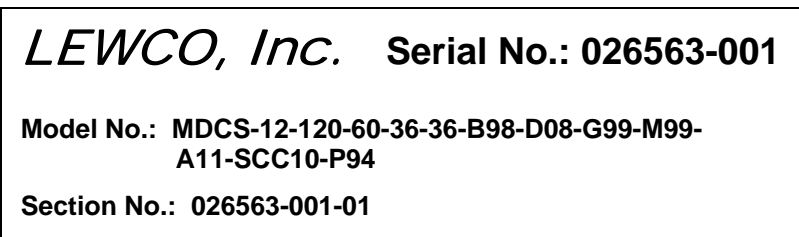

Figure 7.1 Location of Serial Number, Model Number, and Section Number on Typical Unit Label

Standard Spare Part Listings

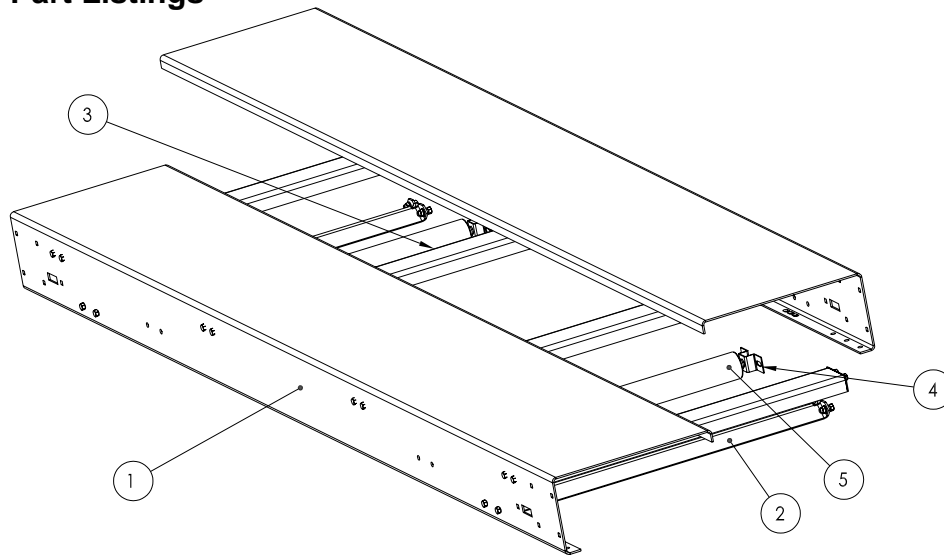

Figure 8.1 HDSB Conveyor (less drive and supports)

ITEM	PART NO.	DESCRIPTION
1	CVP0255-RC-LG	RAIL, STYLE N, INT, 8GAx7.25x1.5
2	CVP0127-LG	CROSSTIE, ANGLE, 35 TIE
3	CVS1182-LG	CROSSTIE, CHAN, WELDMNT, 4X1-1/2
4	CVP0257	ROLLER SLIDE CLIP, HAT SHAPE, 11/16
5	CVS0005-BRG-BF-ROLCOV	ROLLER, R2511, A63 BEARING

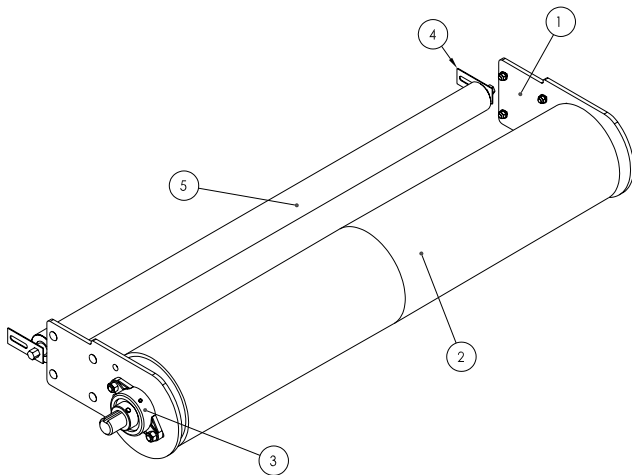

Figure 8.2 Drive Pulley

ITEM	PART NO.	DESCRIPTION
1	CVP0232	DRIVE PL, END, 8 PUL, R4C, 4.5X3.75
2	CVS1208-LG	PULLEY WD, DRIVE, 8 DIAMETER, MDCS
3	PCP0201	BEARING, 2 BOLT FLG, ECC LOCK, 1-7/16
4	CVP0259	ROLLER SLIDE CLIP, FLAT, 11/16
5	CVS0005-BRG-BF-ROLCOV	ROLLER, R2511, A55 BEARING

ITEM	PART NO.	DESCRIPTION
1	CVS0146	TKUP PL WD, LH, 6 PUL, R4C, 4.25X3.75
2	CVS0145	TKUP PL WD, RH, 6 PUL, R4C, 4.25X3.75
3	CVS0140-LG	PULLEY WD, TAKEUP, 6DIA W/ V-GUIDE
4	CVP0230	BEARING SLIDE CLIP, LH, F207, 1/4 PLT
5	CVP0277	BEARING SLIDE CLIP, RH, F207
6	PCP0201	BEARING, 2 BOLT FLG, ECC LOCK, 1-7/16

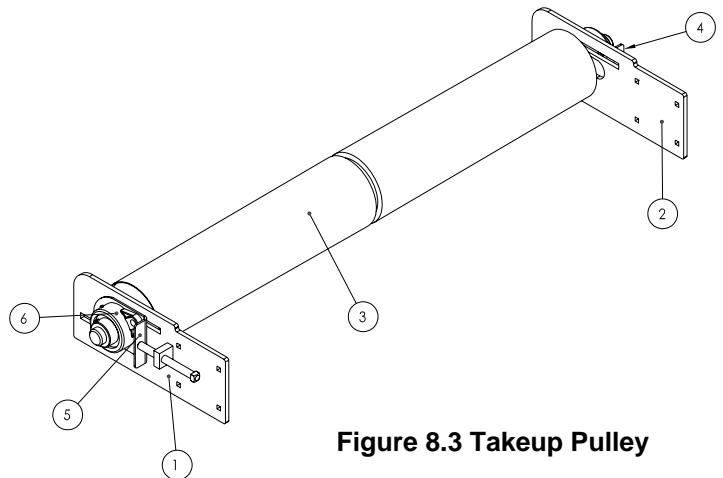
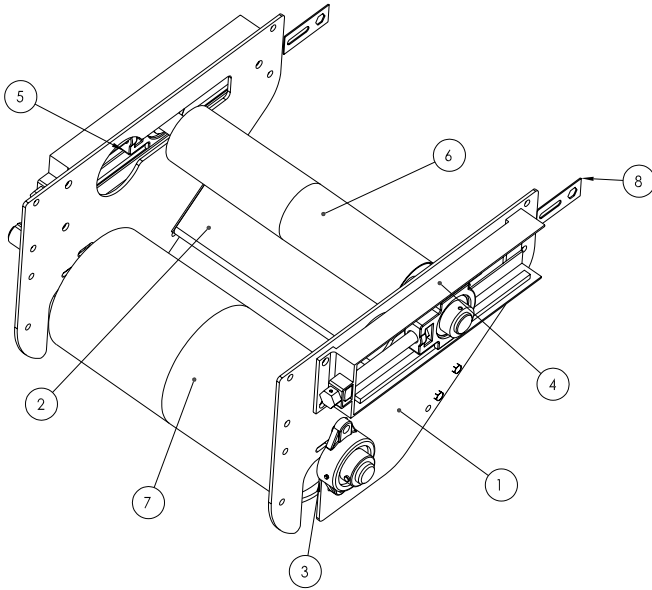

Figure 8.3 Takeup Pulley



ITEM	PART NO.	DESCRIPTION
1	CVP0231	DRIVE PLATE,CENTER,BELT CONVEYOR
2	CVS1182-LG	CROSSTIE,CHAN,WELDMENT,4X1-1/2
3	PCP0201	BEARING,2 BOLT FLG,ECC LOCK,1-7/16
4	PCP0482	TAKE-UP FRAME,12 TRAVEL
5	PCP0202	BEARING,TAKEUP,1-7/16 BORE
6	CVS0245-LG	PULLEY WD,TAKEUP,4DIAMETER,1-7/16"
7	CVS0142-LG	PULLEY WD,DRIVE,8DIAMETER
8	CVP0259	ROLLER SLIDE CLIP,FLAT,11/16

Figure 8.4 Center Drive Pulley
D42 Right Side
D43 Left Side (Shown Above)

ITEM	PART NO.	DESCRIPTION
1	CVS0171-CASE-LG	DRIVE MOUNT,CHAN WELD,GROVE,BTM MNT
2	CVP0264-CASE	DRIVE TENSIONER,GROVE REDUCER
3	CVS0177-21	DRIVE GRD ASS'Y,NOM. 8" DIA
	CVS0177-GC	DRIVE GRD ASS'Y, OTHER
4	PCP0128-30-3-56C	REDUCER,GROVE BM226,SINGLE REDTN
	PCP0128-RATIO-OS-MOUNT	REDUCER, OTHER
5	PCP0268-11-1-.250	SPROCKET,#60 B STYLE,KWY & 2 SS
	PCP0268-TH-BORE	SPROCKET, OTHER
6	PCP0268-24-1.437	SPROCKET,#60 B STYLE,KWY & 2 SS
	PCP0268-TH-BORE	SPROCKET, OTHER
7	PCP0036	MOTOR,3/4HP,230-460/3/60,56C
8	PCP0721	KEYSTOCK,SQUARE,3/8 SQ X 1-3/8 LONG
9	CVP0278	GUARD MOUNTING BRKT,ANG,8-3/8

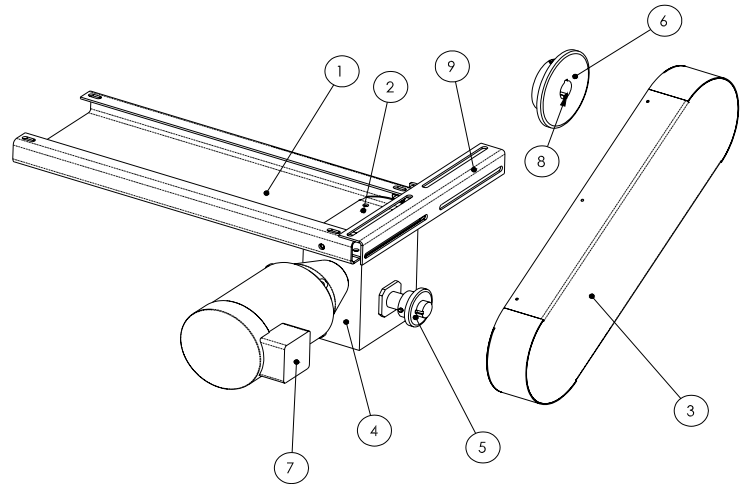

Figure 8.5 End Drive
D46 Right Side (Shown Above)
D41 Left Side

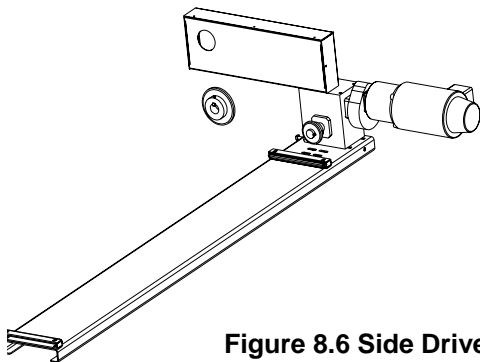

Figure 8.6 Side Drive
D44 Right Side (Shown Above)
D45 Left Side

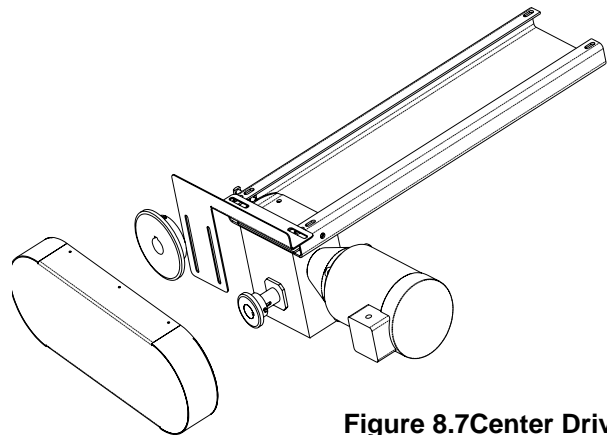

Figure 8.7 Center Drive
D42 Right Side
D43 Left Side (Shown Above)

Note: Motor, speed reducer, driver, and driven sprockets will vary depending on drive option, conveyor speed and motor horsepower. Contact our parts department for specific components listed by the assigned serial number.

ABBREVIATION KEY

ABBREVIATION	DESCRIPTION
BF	BETWEEN FRAME
LG	LENGTH
BRG	BEARING
DAW	OVERALL WIDTH
SPKT	SPROCKET STYLE
TH	NO. OF TEETH
ROLCOV	ROLLER COVER
PTCH	NO. OF PITCHES
CASE	REDUCER CASE SIZE
NS	NO. OF STRANDS
RATIO	REDUCTION RATIO
OS	OUTPUT SHAFT ASSY
MOUNT	MOTOR MOUNT SIZE
TH	NO. OF TEETH
GC	GUARD CENTER TO CENTER
BORE	BORE SIZE
CC	CHAIN CENTER
BW	BELT WIDTH
RCC	ROLLER CENTER TO CENTER